

On Energy Efficiency of BPM Enactment in the Cloud

Olena Skarlat^(✉), Philipp Hoenisch, and Schahram Dustdar

Distributed Systems Group, Institute of Information Systems, TU Wien,
Argentinierstr. 8/184-1, 1040 Vienna, Austria

{o.skarlat,p.hoenisch,dustdar}@infosys.tuwien.ac.at

<http://www.infosys.tuwien.ac.at>

Abstract. Today, a new infrastructure provisioning approach called Cloud Elasticity is evolving, covering three dimensions of elasticity: resource, cost, and quality. Recently, Cloud Elasticity has been utilized for Business Process Enactment in the Cloud as the involved services face highly volatile demand levels. Through treating the three dimensions equally, so-called Elastic (Business) Processes can be achieved, i.e., by leasing and releasing resources on-demand, and customer's requirements regarding quality and cost can now be met more easily. However, information technology infrastructures are now counted as a problem linked to global warming, and accounting for energy efficiency is an adequate response towards "Green" initiatives. This paper is focused on the fulfillment of the principles of Green Computing and Green Business Process Management on the basis of Cloud Elasticity to support Elastic Processes. We describe an approach for the enactment of energy-efficient Elastic Processes by means of the ViePEP platform.

Keywords: Energy efficiency · Elastic processes · Business Process Enactment · Cloud Computing

1 Introduction

Contemporary data centers are complex systems that allow to organize the uninterrupted operation of server and telecommunication facilities. Data centers have to meet the demands of highly converged infrastructures. These can be represented as a fusion of two current trends in Information and Communication Technologies (ICT) – maximization of efficiency and improving the ability to adapt to business dynamics. Cloud Elasticity is an approach used to identify and to implement on-demand runtime adjustment of infrastructural components of Cloud-based data centers through three dimensions: resource, quality, and cost elasticity [1]. Business Process Enactment describes the execution of (potentially resource-intensive) tasks that become dominating in business and scientific domains. ICT infrastructures featuring Cloud Elasticity allow to deploy resource-intensive tasks on-demand and provide a foundation for so-called "Elastic Processes" [2].

The resource dimension of Cloud Elasticity has a correlation with Quality of Service (QoS), i.e. quality elasticity, in a sense that on-demand leasing and releasing of resources has to be done with regard to QoS constraints. The third dimension is cost elasticity which implies using dynamic pricing to change the costs for the provisioned resources meeting QoS constraints [1].

In the last decade, the problem of energy efficiency of ICT infrastructures has gained much attention by both the software industry and the research community. This can be traced back to a noticeable growth of ICT infrastructures and an increase of energy prices. Hence, a necessity for the analysis of energy efficiency is obvious. In fact, aspects of environmental sustainability, reduction of use of harmful materials, and minimization of energy consumption are the main goals of an evolving paradigm named Green ICT [3]. European research and innovation programmes involve considerable efforts and funding for energy, resource, and waste efficiency of Green ICT area. For example, the FP7 project *Adapting Service lifeCycle towards Efficient Clouds* (ASCETiC)¹ is aimed at minimizing energy consumption by means of optimization of design, implementation, and monitoring of the software in Clouds. *Experimental Awareness of CO₂ in Federated Cloud Sourcing* (ECO2Clouds)² also aims at the optimization of CO₂ emissions and of energy consumption. Another project, *Context-Aware Cloud Topology Optimization and Simulation* (CACTOS)³ is focused on the heterogeneity of data center hardware and on the delivery of Cloud-based applications taking into account overall energy consumption. Finally, EU Horizon2020 project *Self-Organizing, Self-Managing Heterogeneous Cloud* (CloudLightning)⁴ plans to implement resource provisioning approaches within Clouds to reduce power consumption and deliver savings to Cloud providers and Cloud consumers.

Still, energy efficiency aspects of Business Process Enactment using Cloud-based computational resources are not explicitly addressed, since the aforementioned EU projects are concentrated around the idea of optimization of the use of Cloud resources, without addressing Business Process Management (BPM) aspects.

Cloud-based BPM offers to companies Platform-as-a-Service or Software-as-a-Service solutions for process support within agile Cloud infrastructures [4]. Consolidation of Cloud and BPM follows a MinMax optimization approach: minimization of capital and infrastructure expenses and maximization of flexibility and reaction towards rapid changes of the demands of the customers [5]. Green BPM [3, 6] is based on mapping the requirements of Green Computing to BPM. The novelty of this approach is emphasized by the non-existence of sophisticated approaches, and potential challenges in the area do not take into consideration Cloud-based aspects.

This paper is aimed at investigating the principles of Green BPM, especially in the field of energy management techniques. In an earlier work, we described the

¹ <http://ascetic-project.eu/>.

² <http://eco2clouds.eu/>.

³ <http://www.cactosp7.eu/>.

⁴ <http://cloudlightning.eu/>.

Vienna Platform for Elastic Processes (ViePEP) [5, 7, 8] – a BPM-driven system that allows to model and enact Elastic Processes taking into account the whole BPM lifecycle. ViePEP provides the functionality to select services for service orchestration, i.e., business processes, with regard to Cloud Elasticity. ViePEP performs optimization of scheduling and resource provisioning. In this work we extend the components of ViePEP to meet the requirements of Green BPM, specifically to address the energy efficiency problem.

Our contributions in this work are: (1) we consider the state-of-the-art in the area of consolidation of the Cloud and BPM technologies meeting “Green” principles, in particular, energy efficiency; (2) we discuss extensions to the Elastic Process lifecycle with regard to Cloud Elasticity and energy efficiency; (3) we show how extensions to the components can be implemented in ViePEP.

The remainder of this work is organized as follows: we give our comment on the related work in the field of energy efficiency in the Cloud with regard to “Green” principles (Sects. 2 and 3). We propose an extension to our former work on Elastic Process scheduling to integrate energy efficiency techniques (Sect. 4), which is followed by an overview of the implementation of the reasoning mechanism by means of ViePEP (Sect. 5). Last but not least, we identify open challenges in the area and present an outlook on our future work (Sect. 6).

2 Related Work

The interest towards Cloud Elasticity is characterized by a rapid change of the demands to ICT services and is enforced by Service Level Agreements (SLAs). Elasticity in power consumption based on the automatic predictive and reactive policies for resource resizing is considered in [9]. The problem of autonomous resource provisioning in Cloud Computing is addressed in [10], where service deployment is introduced as a control system with a closed loop, and Virtual Machines (VMs) are allocated in a way the total count of VMs is minimized. Dynamic reallocation of VM proposed in [11] shows how to migrate VMs and shut down servers using heuristics.

Research work in the area of Cloud and BPM integration regarding Green ICT aspects is still at the beginning. State-of-the-art research in energy efficiency in Cloud Computing can be divided into three main directions: hardware-, software-, and communication-oriented. Crucial research questions within these directions are virtualization and abstraction in data centers, mechanisms for soft turning-off system network components and design of new communication protocols, and elaboration of new replication and data storage algorithms, implementation of plug-in applications and energy-control centers [12]. The same approach of virtualization in data centers for energy consumption minimization, but with respect to the requirement to maintain high QoS levels, is considered in [11].

Management issues on Green ICT, namely an infrastructure for Cloud monitoring [13], a Green Cloud framework [14], and a data center architecture [15] present the concept of VM consolidation to collect from physical servers data dealing with energy consumption. The first step of server consolidation management is to analyze server workload and then to decide on which physical

machine to migrate servers and which to shut down. There are energy management schemes to be considered as challenging in the area: voltage scaling [16, 17], frequency scaling [11], and dynamic turn-off [11, 12]. These energy management schemes are intended to reactively change the voltage and frequency during the operation time of CPUs depending on their utilization level.

Green ICT's main objective is to reduce carbon emissions. The correlation between CO₂ emissions and power consumption is shown in [18]. Two metrics dealing with energy (and CO₂ emissions) are considered: per bit of data transfer and per second of task execution. However, there is no suggestion how to apply this model and how to measure these two energy parameters.

Another point of view of workload management [19] considers temperature awareness and focuses on the analysis of geo-specific temperature regimes, i.e. how outdoor temperature affects cooling system efficiency. The energy consumption of cooling systems, which is about 30% [16, 20] of the consumption of the whole data center, may be optimized applying a joint optimization algorithm. Another localization approach on the basis of local thermal profiles is discussed in [21], where an optimization using a placement function is performed. The placement of virtual resources on the basis of thermal-awareness finds its reflection in workload profiles, thus leading to a reduction in energy consumption. In an earlier work [20], a power-thermal management framework is proposed on the basis of a server consolidation approach to achieve overall minimization of power consumption by means of a thermal manager. In this framework, thermal measurement is presented to maintain one temperature threshold level in the whole data center. The dependency between latency, power consumption, and temperature is discussed in [22]: power consumption has a linear correlation with latency of CPUs, but as far as CPU temperature and frequency parameters are concerned, the relationship turns to be quadratic.

The paradigm of Green BPM deals with the achievement of overall infrastructural and collaborative sustainability and creation of new BPM standards, yet with step-by-step evolution of existing standards and mechanisms [23]. In addition, Berl et al. [12] mention that the popularity of business processes within the business environment places an emphasis on the question of mapping business processes to the software and hardware resources regarding energy-aware constraints and, therefore, becomes a novel research problem. According to the authors, enhancement of existing models by adding environmental metrics and by enrichment of planning optimization algorithms by additional *Energy Indicators* (EIs) are the key challenges to be addressed.

The adaptation towards environmental saving strategies may be considered through four phases: strategy investigation in terms of EIs, process model adaptation and application of dynamic provisioning techniques, analysis of the runtime to meet green metrics, and monitoring of the indicators and metrics [24]. To perform such adaptation and to optimize business processes in terms of the environmental impact the use of environment-aware business process patterns is proposed in [25]. The authors state that the explicit application of Green BPM

Table 1. An overview of related work

Ref.	Technology	Method	Component	Metrics
[9]	Clusters, Amazon EC2	Prediction, policy	Elastic site prototype	Workload
[10]	Cloud	Proactive, reactive scaling	Elastic Cloud controller	Performance, workload
[11]	Data center	Heuristics, policy	Fast heuristics algorithms	Performance
[13]	IBM Cloud	Server consolidation	Monitoring infrastructure	Performance
[14]	Data center	Temperature, image management	Green Cloud framework	Performance
[15]	Data center	Server consolidation, live migration	VM-based energy-efficient data center	Performance
[16]	Data center	Voltage, frequency scaling, dynamic shutdown	GreenCloud	Performance, workload
[17]	Clusters, Cloud	Voltage, frequency scaling	Smart metering system	Performance
[18]	Data center	CO ₂ optimization	Carbon efficient green policy	Performance, workload
[19]	Data center	Outside aircooling optimization	Empirical cooling efficiency model	Workload, temperature
[20]	Data center	Temperature-aware resource provisioning	Power thermal management Framework	Performance, temperature
[21]	Clusters	Thermal-aware heuristics	Thermal-aware placement algorithm	Workload, temperature
[22]	Map-reduce clusters	Periodic optimization with latest CPU temperatures	Temperature-aware power allocation framework	Workload, temperature

research is still in its beginning and the evaluation of the ecosystem sustainability, that can be achieved by means of green initiatives, remains a challenge.

In Table 1, we summarize approaches investigated in related research in Cloud Computing regarding energy efficiency. Common methods can be distinguished here: server consolidation and live migration, proactive and reactive resource allocation, as well as voltage and frequency scaling, i.e. energy management. The correlation between temperature, workload, and power consumption is explicitly regarded: Optimization deals with the business model of data centres and their ability to provide services in a way that reduces the trade-off between saving energy and performance and workload metrics, decreasing cost expenses from the user and data center sides. These approaches can be used to achieve energy efficiency on the physical and virtual levels of Cloud infrastructures by affecting the scheduling and reasoning mechanisms in the Cloud.

3 Problem Statement

Green BPM implies the adaptation of existing Cloud Computing and BPM solutions by aggregating them with “green components”. On the basis of our investigation of the related work in the domain of energy efficiency and Green Computing initiatives, we are now able to set research objectives towards the extensions of components that we use in ViePEP. We consider Cloud-based data centers in terms of ICT infrastructure, and ViePEP as the basis towards the optimized enactment of Elastic Processes. Accounting for the investigated variability of

used techniques to approach green metrics, the main objective of resource allocation in Clouds remains the priority of a service delivery to the customers with regard to SLAs and QoS.

In Sect. 1 we discussed that energy awareness is a major trend in European research projects. One of the objectives of the ASCETiC project is to develop a framework that considers energy efficiency metrics in the Cloud and to deal with energy as a part of quality dimension of elasticity elaborated within SLAs. The approach is to obtain an estimation of the energy consumption of particular elements of the infrastructure during runtime. Here, EIs are divided into three levels: application, virtual, and physical. The migration strategy is based on accounting for energy probes, i.e. actual energy measurements.

Another project (CACTOS) uses heuristic algorithms to optimize the cost function on the basis of predicted cost of energy consumption of VMs and on the node level. This becomes a foundation for deployment planning. They propose to use an EIs model that takes into account power consumption of starting VMs, during migration process, and shutdowns.

The ECO2Clouds project considers different metrics of power consumption of VMs and infrastructure through monitoring. The set of metrics include infrastructural, virtualization, and application layer metrics. Data that is collected by these metrics is used to adapt the deployment and the runtime of an application. The overall optimization process here is concentrated on maximization of use of the single physical resources, i.e. allocating VMs on the host that features the highest energy consumption.

The overview of the European projects and related work showed common approaches towards achieving energy efficiency. The purpose of the related work analysis was to extract trends to improve ViePEP, which is a research Business Process Management System (BPMS). Our previous work on ViePEP presented a reasoning mechanism for scheduling and optimal resource leasing and releasing from the user point of view, i.e. the overall optimization was conducted in order to minimize cost [5]. We extend our previous work by extending Elastic Process scheduling and resource allocation by the notion of energy efficiency. For this, we also need to extend ViePEP by dedicated components which take into account the energy efficiency problem from the service provider side.

4 Extension Mechanism for Energy Efficiency of BPM

ICT infrastructural resources can be classified into computational, storage, and network resources. Elastic Processes are business processes that are realized on the basis of such ICT infrastructural solutions and are able to react to dynamic changes in the computational and business environment [2].

To realize Elastic Processes, a well-known approach from Autonomic Computing, namely the MAPE-K cycle [27] can be applied: to Monitor, Analyze, Plan, and Execute processes based on a Knowledge Base. To map these steps of the MAPE-K model onto a business process lifecycle, the following phases are considered, which are performed by the administration of the used BPMS and

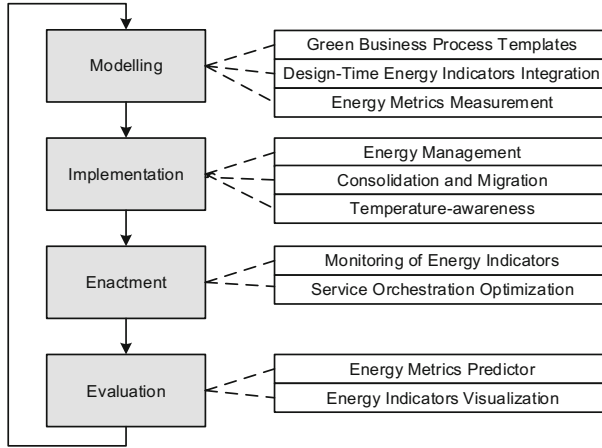

Fig. 1. Extensions to the elastic process lifecycle phases to meet energy efficiency demands (adapted from [6])

owners of the business processes: *Plan* step: process identification and modelling along with the overall process and single process step implementation; *Execute* step: process enactment; *Monitor* step: process monitoring; *Analyze* step: post-enactment evaluation. By applying the suggestions of the green business process lifecycle to the work of Nowak et al. [6], we extend our current approach towards optimization of Elastic Processes as it can be seen in Fig. 1.

The process of leasing and releasing of resources needs to be fulfilled by adaptivity means of the BPMS (here: ViePEP). Thereby, decision making by the BPMS regarding the use of ICT infrastructural resources must follow a Min-Max approach: minimizing resource and cost, and maximizing quality. Energy efficiency can be attributed to the QoS, while energy consumption expenses affect the overall cost optimization function. The *Plan* step includes the actual process modeling and its implementation. Process modeling is the first phase in the Elastic Process lifecycle. The main task of this phase is to perform energy-aware design of business processes. To compose a business process, a *Green BP Templates* selector will be used with predefined energy-aware metrics. A new BPM stakeholder, the *energy management officer*, should be considered here. Her main responsibility is to perform an energy audit within the enterprise, identify Key Performance Indicators (KPIs) dealing with energy consumption (i.e., EIs), and to take appropriate measures to fulfill these specified indicators. Single process steps as well as the service orchestration need to have methods to incorporate the values of EIs within the design-time environment. EIs of various types will be stored in the *Energy Indicators Registry*, applying to the application level, VMs and physical machines. During business process composition, usage of energy metrics will be indicated via data that is received from sensors (*Energy Metrics Controller*) regarding specific parts of the infrastructure. Depending on the design of the business process, a pricing model will be

adapted to different energy profiles. During the business process implementation phase, the optimization of the resource use with regard to energy efficiency can be configured. The approaches to achieve energy efficiency on the physical level (as shown in Table 1) can be associated with single process steps. Within this phase, energy-aware scheduling and live migration can be performed, i.e. choosing physical hosts to deploy VMs. The energy-aware operation of VMs involves dynamic management of VMs on the basis of EIs values. Energy metrics data has to be associated with the business process instances, i.e. to be annotated. Another optional phase of the process lifecycle is the certification of a certain business process model to confirm its energy-consumption characteristics, e.g., by an accredited external party.

The *Execute* step correlates with the *Monitor* step of the MAPE-K model. The enactment phase will involve extended monitoring. For process optimization at runtime, the executions of business process steps (in terms of Cloud-based services) are monitored. Monitoring data is available in the form of data streams. This is followed by EI-driven process data analysis integrated with service composition re-planning which results in a near-optimal process service plan with partial re-deployment at runtime. To achieve quantitative analysis, periodic monitoring is to be performed during design-time, runtime, and post runtime.

The evaluation phase of the Elastic Process lifecycle corresponds to the *Analyze* step of the MAPE-K model. The phase uses received monitoring data to reconfigure business processes. Runtime optimization based on the energy consumption allows dynamically changing a running process instance while being executed. Alternatively, the data acquired at runtime of an instance can be analyzed for future runs of other instances of the process model. To accomplish this, statistical processing will consider historical data and aim at the analysis of real-time data streams and events produced by the environment. The other need is to establish the ability to customize process visualization according to user needs and based on EIs. Future green initiatives may lead to a trade-off in cost and quality of the provided services in terms of penalties which apply if a process deadline can not be met. An according cost optimization function reflects the financial streams that are generated from the activities that are arranged to gain energy efficiency.

5 Enactment of Energy-Efficient Elastic Processes by Means of ViePEP

In general, ViePEP aims at the cost-efficient enactment of Elastic Processes. For an overview of the main components, refer to [5,7].

In order to take into account energy-efficiency, it is necessary to extend ViePEP by according software components (see Fig. 2) as well as enable energy-efficient scheduling and resource allocation.

On the lowest level, an additional output from the *Backend VMs* regarding energy metrics will be received by the *Energy Metrics Controller*. The monitoring aspect will be regarded during design-time: The *Process Manager* will be

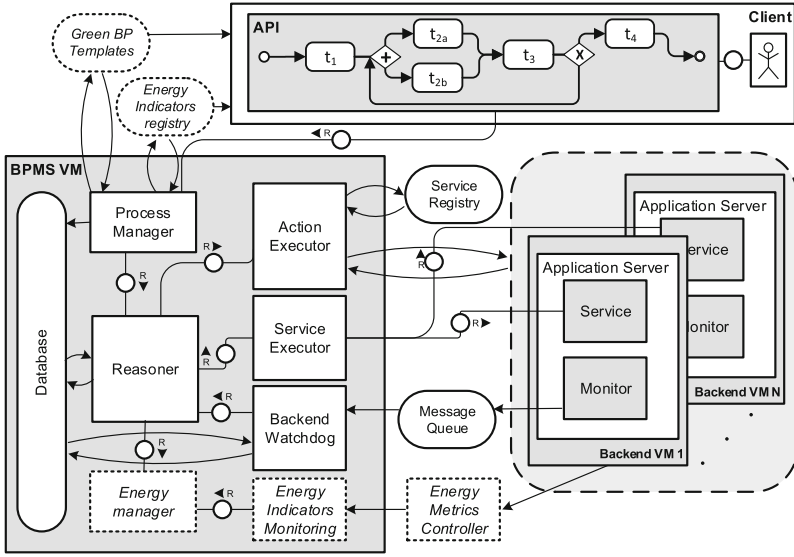

Fig. 2. Extensions to ViePEP to meet energy efficiency demands

extended by an interface to an energy-aware *Green BP Templates* selector in order to have the possibility to choose another alternative of a business process, taking into account energy considerations. The *Energy Indicators Registry* aims at the integration of the information about EIs into a business process instance. The *Backend Watchdog* will be supplemented by the subcomponent *Energy Indicators Monitoring* to specify the influence on the energy efficiency and to monitor dependencies of various actions on the Elastic Process steps. The *Reasoner* component performs the optimization of the complete business process and overall Cloud infrastructure landscape. The *Energy Manager* is a supplement component to the *Reasoner*, and will consider an energy-efficient execution of business processes by allocating resources on-demand with regard to EIs and objective energy profiles.

6 Conclusions and Future Work

The use of Cloud-based Elastic Processes provides the means of dynamic deployment of business processes onto ICT infrastructural resources. To address the problem of consolidation of Cloud and BPM, an application of a MinMax optimization approach is needed: minimization of capital and infrastructure expenses, maximization of flexibility and reaction towards rapid changes of the demands of the customers.

The comment on the related research in the field of Business Process Enactment on the basis of Cloud Elasticity established a foundation for the research plan of improving our research BPMS for Elastic Processes – ViePEP – with

the means to take into account energy efficiency aspects. A mechanism of consolidation of Cloud Elasticity to use energy efficiency techniques was discussed on the basis of the general requirements of Green Computing and Green BPM principles.

The general barriers towards green initiatives can be explicitly divided into structural and financial. Structural barriers describe the fragmentation of the Cloud market. Small data centers are not cost-effective enough to invest in energy efficiency aspects. Therefore, a union of small data centers may be financially more attractive. The other major problem is the lack of an international protocol document regarding measurement of energy efficiency in data centers. This leads to the absence of real stimulus to use energy-efficient domain equipment and controllers. High initial expenses to reconfigure old and buy new equipment and long pay-off period are also considered as a barrier. Additionally, data centers do not account for the financial benefits dealing with the energy efficiency in their financial streams. Consequently, success in achieving energy efficiency is implied by evolutionary approaches of comfortable step-by-step integration of green principles into existing systems.

In our future work, we want to take into account energy efficiency during the Plan and Execute steps of the MAPE-K model. The design of energy-efficient business processes is challenging in terms of the application of Green Business Process patterns [25, 26]. During enactment energy efficiency needs to be taken into account as another constraint for scheduling and resource allocation. Finally, the Monitor and Analyze steps of the MAPE-K model should be improved by means of accounting for KPIs of green initiatives, namely EIs.

Acknowledgment. This paper is supported by TU Wien research funds.

References

1. Copil, G., Moldovan, D., Truong, H.-L., Dustdar, S.: Multi-level elasticity control of cloud services. In: Basu, S., Pautasso, C., Zhang, L., Fu, X. (eds.) ICSOC 2013. LNCS, vol. 8274, pp. 429–436. Springer, Heidelberg (2013)
2. Dustdar, S., Guo, Y., Satzger, B., Truong, H.-L.: Principles of elastic processes. *IEEE Internet Comput.* **15**(5), 66–71 (2011)
3. Houy, C., Reiter, M., Fettke, P., Loos, P.: Towards green BPM – sustainability and resource efficiency through business process management. In: Muehlen, M., Su, J. (eds.) BPM 2010 Workshops. LNBIP, vol. 66, pp. 501–510. Springer, Heidelberg (2011)
4. Baeyens, T.: BPM in the cloud. In: Daniel, F., Wang, J., Weber, B. (eds.) BPM 2013. LNCS, vol. 8094, pp. 10–16. Springer, Heidelberg (2013)
5. Hoenisch, P., Schuller, D., Schulte, S., Hochreiner, C., Dustdar, S.: Optimization of complex elastic processes. *IEEE Trans. Serv. Comput.* **PP**(99), 1–8 (2015). IEEE Press
6. Nowak, A., Leymann, F., Schumm, D.: The differences and commodities between green and conventional business process management. In: 9th IEEE International Conference in Dependable, Autonomic and Secure Computing, pp. 569–576. IEEE Press (2011)

7. Schulte, S., Hoenisch, P., Venugopal, S., Dustdar, S.: Introducing the vienna platform for elastic processes. In: Ghose, A., Zhu, H., Yu, Q., Delis, A., Sheng, Q.Z., Perrin, O., Wang, J., Wang, Y. (eds.) ICSOC 2012. LNCS, vol. 7759, pp. 179–190. Springer, Heidelberg (2013)
8. Hoenisch, P., Schulte, S., Dustdar, S.: Workflow scheduling and resource allocation for cloud-based execution of elastic processes. In: 6th International Conference on Service-Oriented Computing and Applications, pp. 1–8. IEEE Press (2013)
9. Marshall, P., Keahey, K., Freeman, T.: Elastic site: using clouds to elastically extend site resources. In: 10th International Conference on Cluster, Cloud and Grid Computing, pp. 43–52. IEEE Press (2010)
10. Ali-Eldin, A., Tordson, J., Elmroth, E.: An adaptive hybrid elasticity controller for cloud infrastructures. In: IEEE Network Operations and Management Symposium, pp. 204–212. IEEE Press (2012)
11. Beloglazov, A., Buyya, R.: Energy efficient allocation of virtual machines in cloud data centers. In: 10th International Conference on Cluster, Cloud and Grid Computing, pp. 577–578. IEEE Press (2010)
12. Berl, A., Gelenbe, E., Di Girolamo, M., Giuliani, G., De Meer, H., Dang, M.Q., Pentikousis, K.: Energy-efficient cloud computing. *Comput. J.* **53**(7), 1045–1051 (2010)
13. Corradi, A., Fanelli, M., Foschini, L.: Increasing cloud power efficiency through consolidation techniques. In: Symposium on Computers and Communications, pp. 129–134. IEEE Press (2011)
14. Younge, A.J., von Laszewski, G., Lizhe, W., Lopez-Alarcon, S., Carithers, W.: Efficient resource management for cloud computing environments. In: International Green Computing Conference, pp. 357–364. IEEE Press (2010)
15. Ye, K., Huang, D., Jiang, X., Chen, H., Wu, S.: Virtual machine based energy-efficient data center architecture for cloud computing: a performance perspective. In: International Conference on Green Computing and Communications and International Conference on Cyber, Physical and Social Computing, pp. 171–178. IEEE Press (2010)
16. Kliazovich, D., Bouvry, P., Khan, S.U.: GreenCloud: a packet-level simulator of energy-aware cloud computing data centers. *J. Supercomput.* **62**, 1263–1283 (2012)
17. Tu, C.-Y., Kuo, W.-C., Teng, W.-H., Wang, Y.-T., Shiau, S.: A power-aware cloud architecture with smart metering. In: 39th International Conference on Parallel Processing Workshops, pp. 497–503. IEEE Press (2010)
18. Garg, S.K., Yeo, C.S., Buyya, R.: Green cloud framework for improving carbon efficiency of clouds. In: Jeannot, E., Namyst, R., Roman, J. (eds.) Euro-Par 2011, Part I. LNCS, vol. 6852, pp. 491–502. Springer, Heidelberg (2011)
19. Xu, H., Feng, C., Li, B.: Temperature aware workload management in geodistributed datacenters. In: ACM SIGMETRICS/International Conference on Measurement and Modeling of Computer Systems, pp. 373–374. ACM (2013)
20. Pakbaznia, E., Ghasemazar, M., Pedram, M.: Temperature-aware dynamic resource provisioning in a power-optimized datacenter. In: Design, Automation, and Test in Europe Conference and Exhibition, pp. 124–129. IEEE Press (2010)
21. Kaushik, R.T., Nahrstedt, K.: T*: a data-centric cooling energy costs reduction approach for big data analytics cloud. In: International Conference for High Performance Computing, Networking, Storage and Analysis, pp. 1–11. IEEE Press (2012)
22. Li, S., Wang, S., Abdelzaher, T., Kihl, M., Robertsson, A.: Temperature aware power allocation: an optimization framework and case studies. *Sustain. Comput. J.* **2**, 117–127 (2012)

23. Jakobi, T., Castelli, N., Nolte, A., Stevens, G., Schonau, N.: Towards collaborative green business process management. In: 28th EnviroInfo ICT for Energy Efficiency Conference, pp. 683–690. BIS-Verlag (2014)
24. Nowak, A., Leymann, F., Schumm, D., Wetzstein, B.: An architecture and methodology for a four-phased approach to green business process reengineering. In: Kranzlmüller, D., Toja, A.M. (eds.) ICT-GLOW 2011. LNCS, vol. 6868, pp. 150–164. Springer, Heidelberg (2011)
25. Nowak, A., Leymann, F., Schleicher, D., Schumm, D., Wagner, S.: Green business process patterns. In: 18th Conference on Pattern Languages of Programs, article no. 6. ACM, New York (2011)
26. Nowak, A., Breitenbücher, U., Leymann, F.: Automating green patterns to compensate CO₂ emissions of cloud-based business processes. In: 8th International Conference on Advance Engineering Computing and Applications in Sciences, pp. 132–139. IARIA (2014)
27. Kephart, J.O., Chess, D.M.: The vision of autonomic computing. *Computer* **36**(1), 41–50 (2003)